

**NOTS:**

- 1- Insulation for tank shell from the top of lower skid ring to the top and the top cap
- 2- Insulation for drain sump
- 3- Alkaline resistant liner for all wetted parts
- 4- Insulation cover is AISI 304 and is welded to the body Using E309L-16 electrodes
- 5- After tank intallation, outside the base frame must be insulated
- 6- The insulation should be covered with 2 mm SS 304 plate

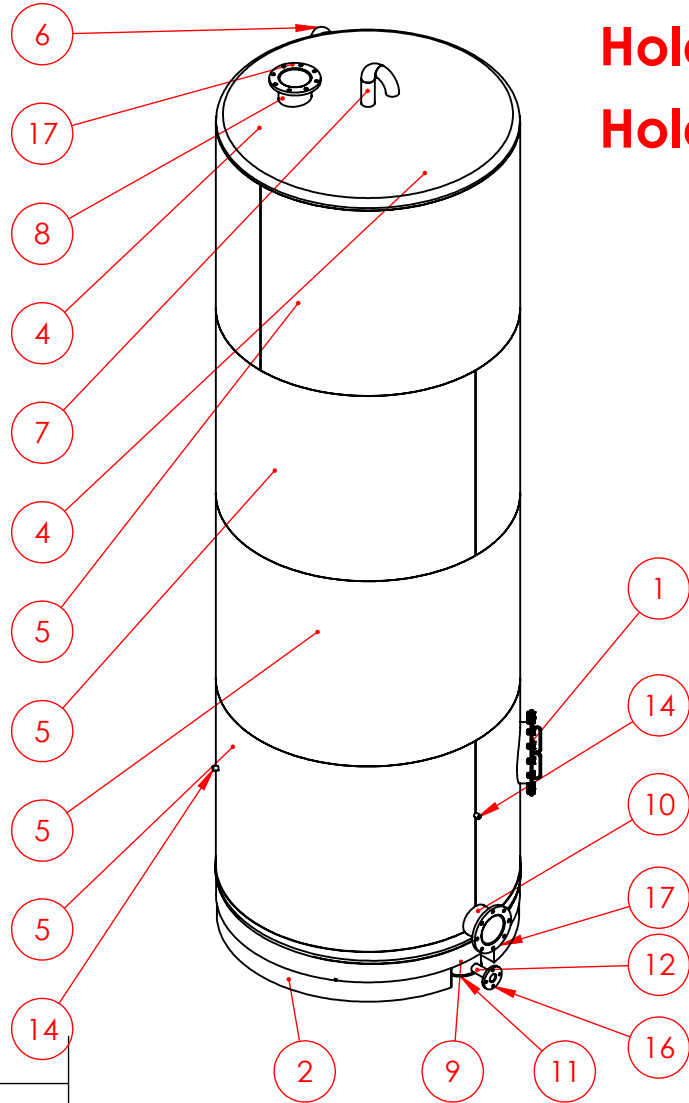

**Hold**  
**Hold**

17	RYC-PH4-ST1-WSD-PRO-33-101-015-D00		Flange 1	DN 200 ; DIN 2576	A560	2	9.20	18.4
16	RYC-PH4-ST1-WSD-PRO-33-101-014-D00		Flange 2	DN 50 ; DIN 2576	A560	1	2.43	2.43
15	RYC-PH4-ST1-WSD-PRO-33-101-013-D00		Pressure Socket	Class 150 ; 1 1/2" Female	A560	1	0.21	0.21
14	RYC-PH4-ST1-WSD-PRO-33-101-012-D00		Temperature Socket	Class 150 ; 3/4" Female	A560	2	0.07	0.14
13	RYC-PH4-ST1-WSD-PRO-33-101-011-D00		Level Socket	Class 150 ; 1 1/2" Female	A560	1	0.21	0.21
12	RYC-PH4-ST1-WSD-PRO-33-101-010-D00		Drain Pipe	DN 50 ; SCH40	A560	1	0.93	0.93
11	RYC-PH4-ST1-WSD-PRO-33-101-009-D00		Cap Plate	---	A560	1	4.74	4.74
10	RYC-PH4-ST1-WSD-PRO-33-101-008-D00		Outlet Pipe	DN200 ; SCH40	A560	1	6.96	6.96
9	RYC-PH4-ST1-WSD-PRO-33-101-007-D00		Drain	DN250 ; SCH40	A560	1	14.96	14.96
8	RYC-PH4-ST1-WSD-PRO-33-101-006-D00		Inlet Pipe	DN200 ; SCH40	A560	1	6.64	6.64
7	RYC-PH4-ST1-WSD-PRO-33-101-005-D00		Vent Pipe	DN80 ; SCH40	A560	1	6.18	6.18
6	RYC-PH4-ST1-WSD-PRO-33-101-004-D00		Overflow Pipe	DN100 ; SCH40	A560	1	5.34	5.34
5	RYC-PH4-ST1-WSD-PRO-33-101-003-D00		Tank Body	---	A560	4	436.61	1746.44
4	RYC-PH4-ST1-WSD-PRO-33-101-002-D00		Top Cap	---	A560	1	105.38	105.38
3	RYC-PH4-ST1-WSD-PRO-33-101-001-D00		Bottom Cap	---	A560	1	276.39	276.39
2	RYC-PH4-ST1-WSD-PRO-33-101-200-D00		Bottom Support	---	---	1	397.16	397.16
1	RYC-PH4-ST1-WSD-PRO-33-101-100-D00		Side Handhole 400	---	---	1	37.46	37.46
Item	Drawing Number	Rev.	Part Name	Description	Material	QTY.	Weight (Kg)	



**Razavi Yeast Company**

**Expansion Project  
Phase IV, Step 1**

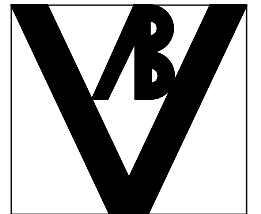

**Client: Razavi Yeast Co**

**Supplier: ABV Eng & Technology**

	NAME	MATERIAL	TITLE :	TAG NUMBER :
	---	---	<b>Chilled Water Tank 2</b>	<b>33-T-101</b>
DESIGN	ABV	WEIGHT (Kg)	ASS. NAME :	PART NAME:
DRAW	HAM	2629.96	<b>Chilled Water</b>	<b>Chilled Water</b>
CHECK	ABV		DWG No. : RYC-PH4-ST1-WSD-PRO-33-101-000-D00	
APP.	RYC		SCALE 1:50	SHEET 1 OF 2
				SIZE : A4

Index	Date	Comment / Change

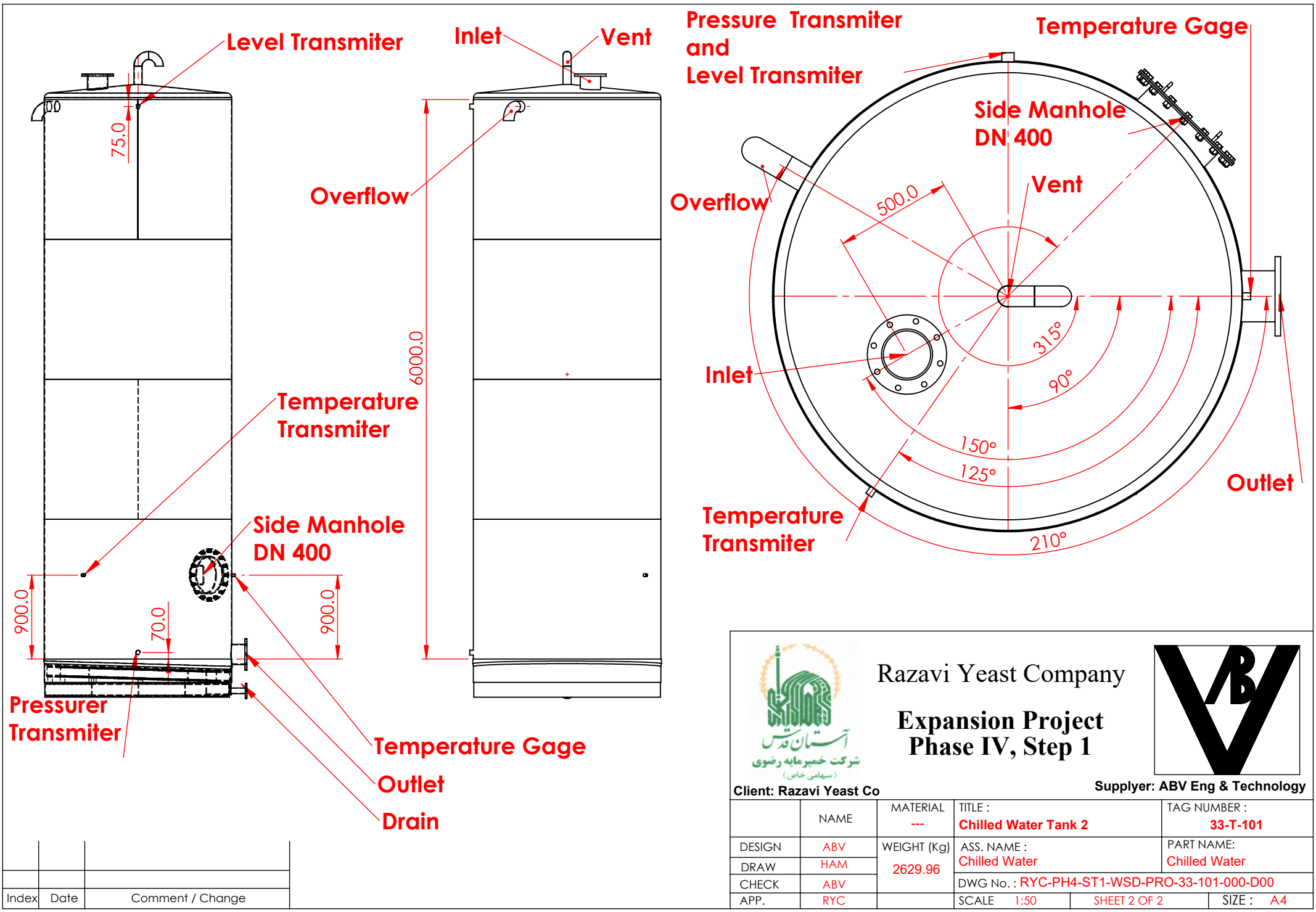

Index	Date	Comment / Change



شركت خميرمايه رضوي  
(سهلاني خاص)

Razavi Yeast Company

**Expansion Project  
Phase IV, Step 1**

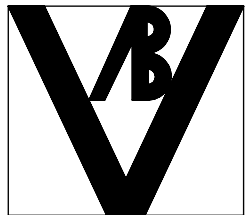

Client: Razavi Yeast Co Supplier: ABV Eng & Technology

	NAME	MATERIAL	TITLE :	TAG NUMBER :
	---	---	<b>Chilled Water Tank 2</b>	<b>33-T-101</b>
DESIGN	ABV	WEIGHT (Kg)	ASS. NAME :	PART NAME:
DRAW	HAM	2629.96	<b>Chilled Water</b>	<b>Chilled Water</b>
CHECK	ABV		DWG No. : <b>RYC-PH4-ST1-WSD-PRO-33-101-000-D00</b>	
APP.	RYC		SCALE 1:50	SHEET 2 OF 2
				SIZE : <b>A4</b>

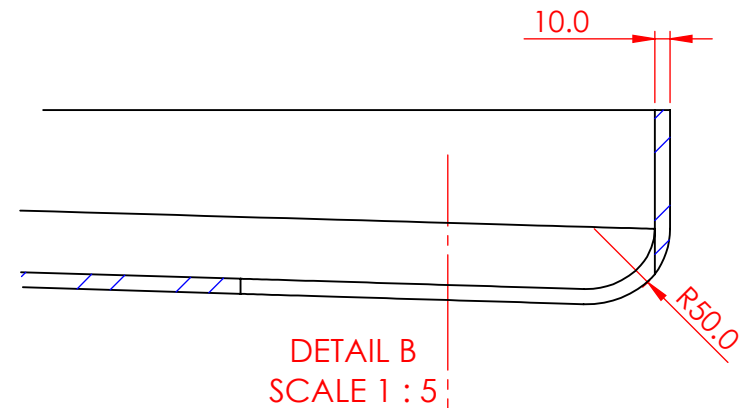
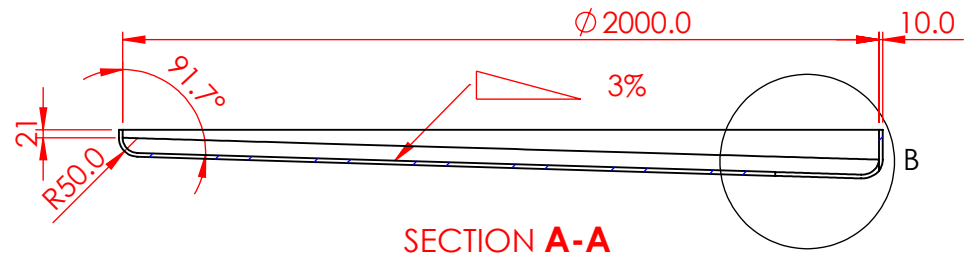
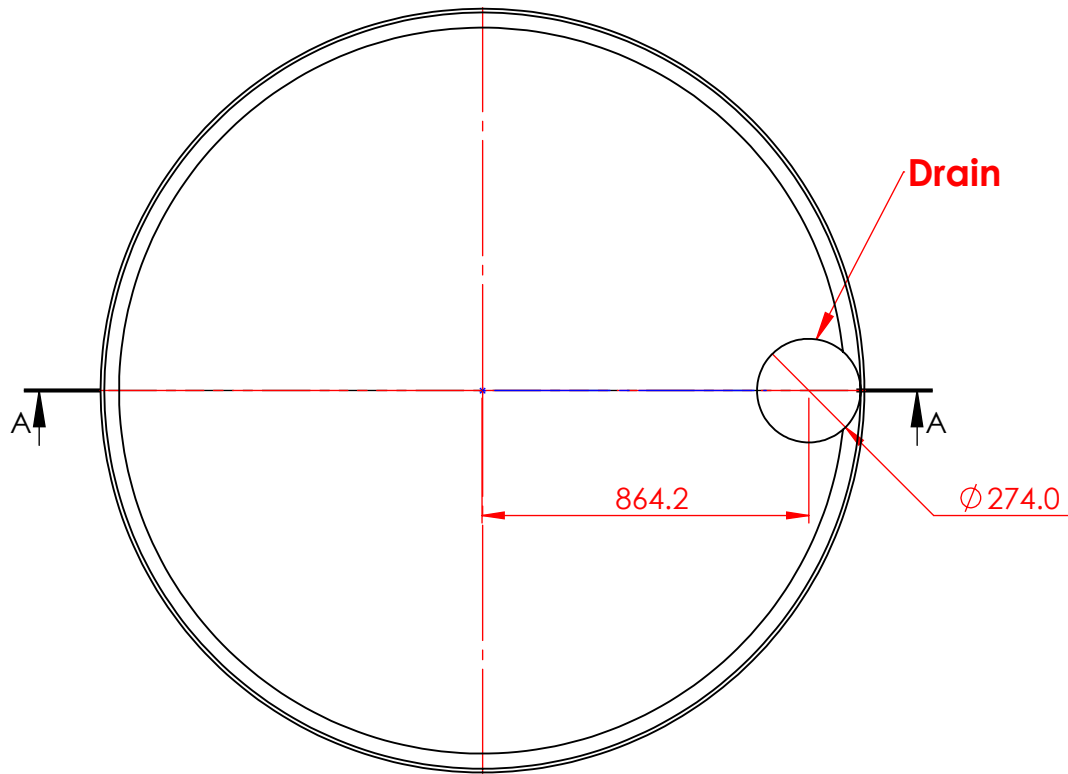

+



Razavi Yeast Company

Expansion Project  
Phase IV, Step 1



Client: Razavi Yeast Co

Supplier: ABV Eng & Technology

	NAME	MATERIAL A560	TITLE : Chilled Water Tank 2	TAG NUMBER : 33-T-101
DESIGN	ABV	WEIGHT (Kg) 276.39	ASS. NAME : Chilled Water	PART NAME: Bottom Cap
DRAW	HAM		DWG No. : RYC-PH4-ST1-WSD-PRO-33-101-001-D00	
CHECK	ABV		SCALE 1:20	SHEET 1 OF 1
APP.	RYC			SIZE : A4

Index	Date	Comment / Change

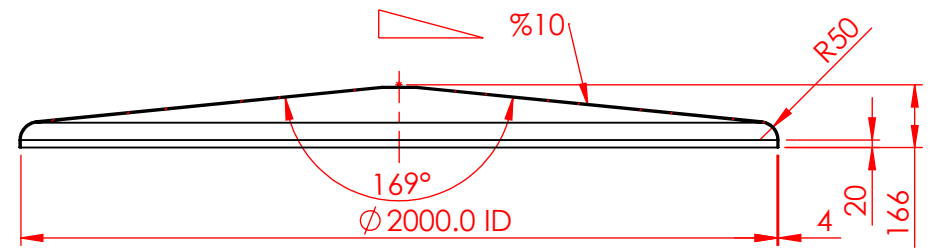
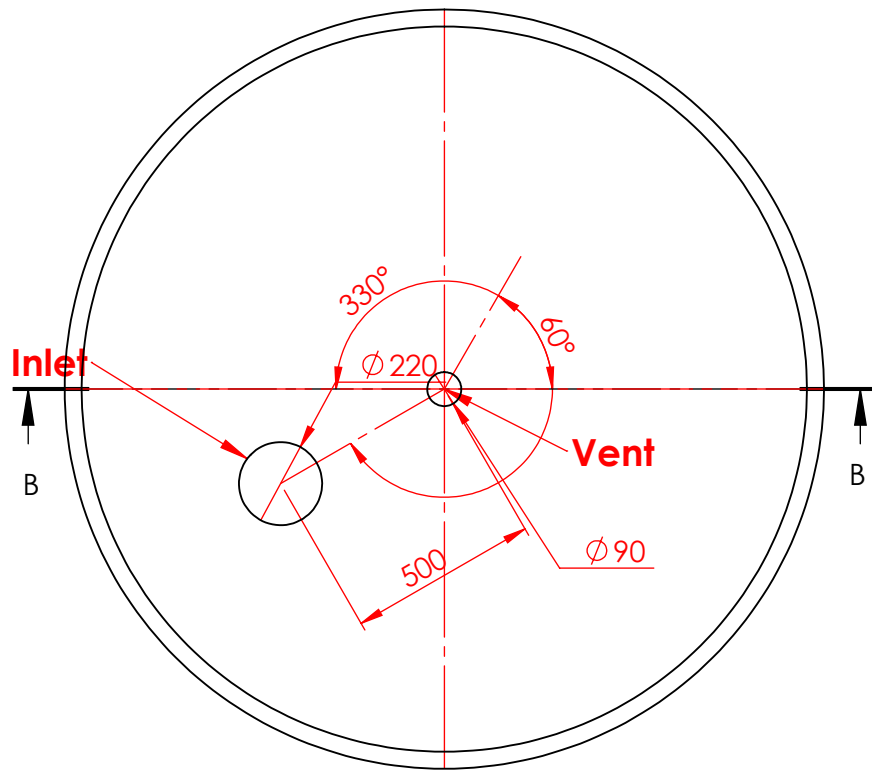

SECTION B-B



Razavi Yeast Company

Expansion Project  
Phase IV, Step 1

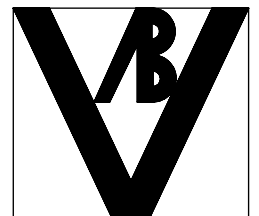

Client: Razavi Yeast Co

Supplier: ABV Eng & Technology

	NAME	MATERIAL A560	TITLE : Chilled Water Tank 2	TAG NUMBER : 33-T-101
DESIGN	ABV	WEIGHT (Kg) 105.38	ASS. NAME : Chilled Water	PART NAME: Top Cap
DRAW	HAM		DWG No. : RYC-PH4-ST1-WSD-PRO-33-101-002-D00	
CHECK	ABV		SCALE 1:20	SHEET 1 OF 1
APP.	RYC			SIZE : A4

Index	Date	Comment / Change

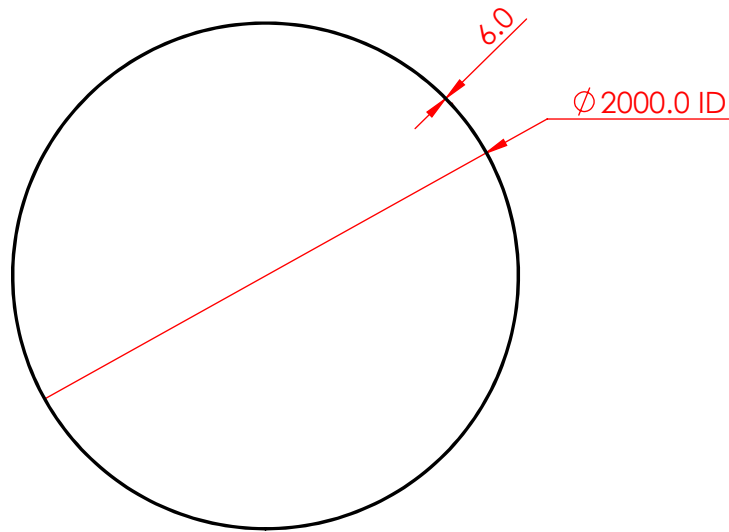
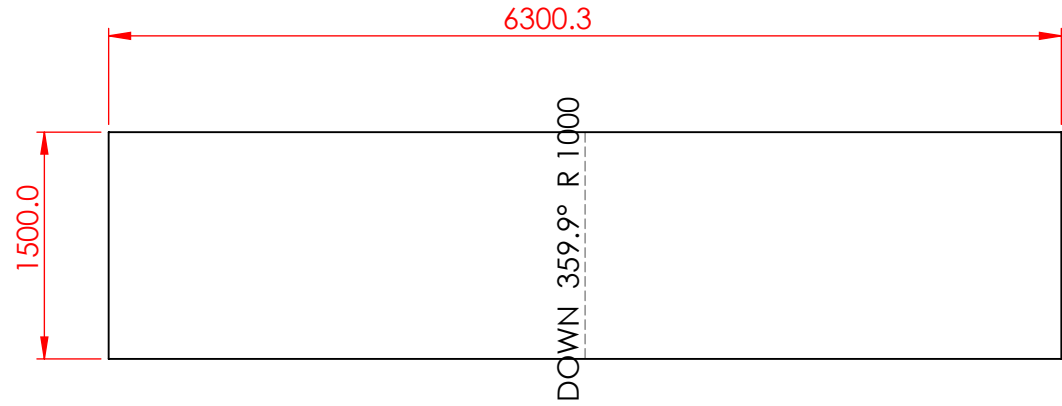
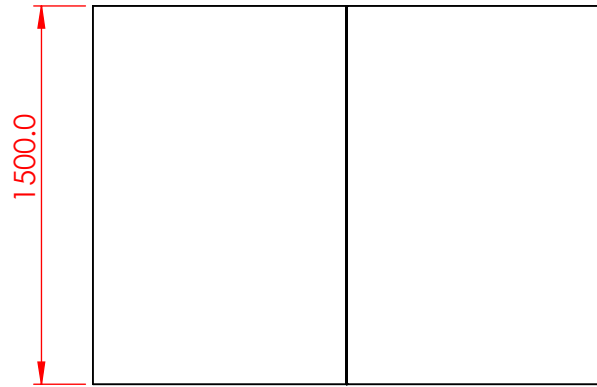

Razavi Yeast Company

Expansion Project  
Phase IV, Step 1



Client: Razavi Yeast Co

Supplier: ABV Eng & Technology

	NAME	MATERIAL A560	TITLE : Chilled Water Tank 2	TAG NUMBER : 33-T-101
DESIGN	ABV	WEIGHT (Kg) 436.61	ASS. NAME : Chilled Water	PART NAME: Tank Body
DRAW	HAM			
CHECK	ABV		DWG No. : RYC-PH4-ST1-WSD-PRO-33-101-003-D00	
APP.	RYC		SCALE 1:30	SHEET 1 OF 1
				SIZE : A4

Index	Date	Comment / Change

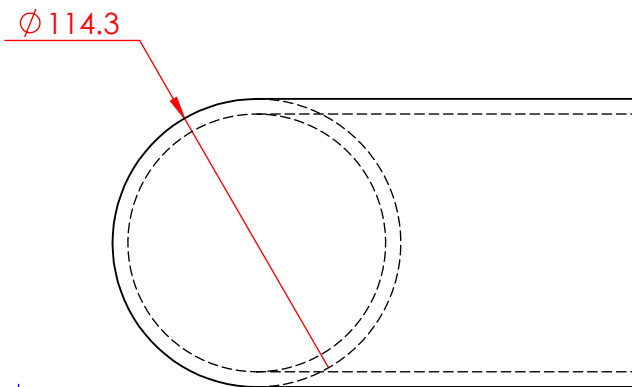
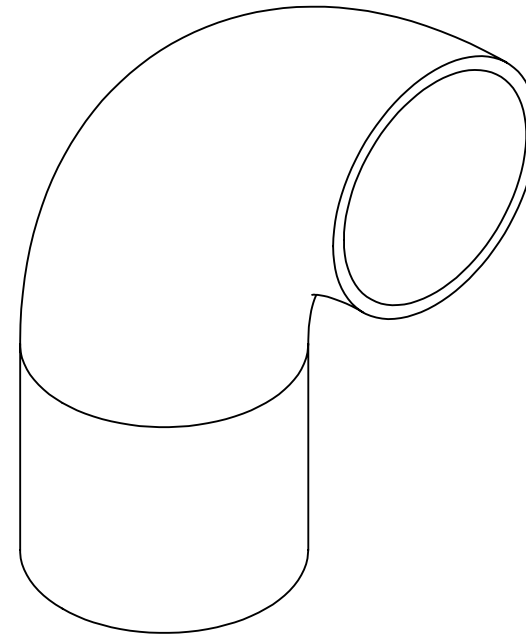
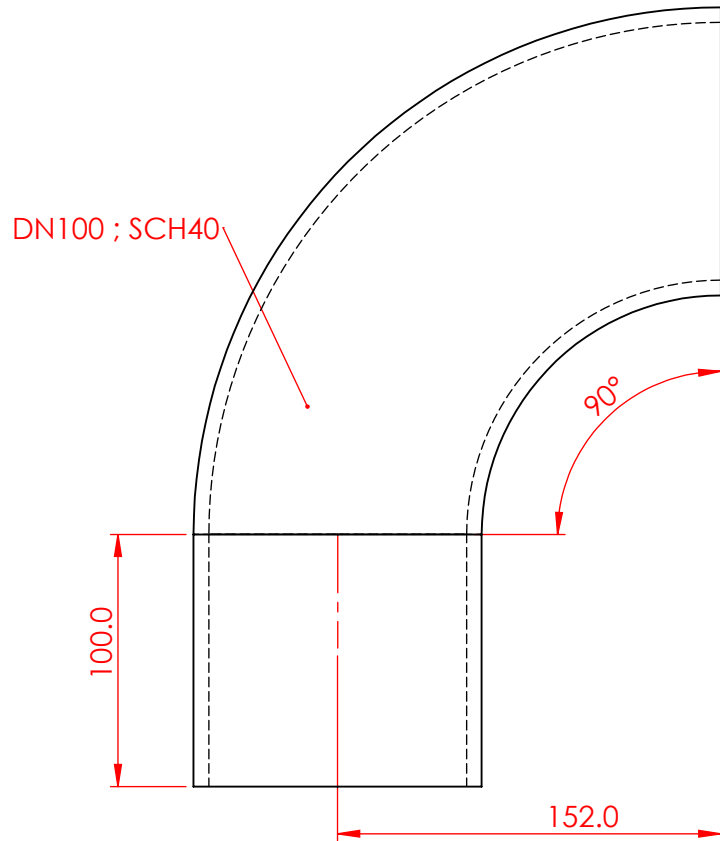

Razavi Yeast Company

**Expansion Project  
Phase IV, Step 1**



Client: Razavi Yeast Co

Supplier: ABV Eng & Technology

	NAME	MATERIAL A560	TITLE : Chilled Water Tank 2	TAG NUMBER : 33-T-101
DESIGN	ABV	WEIGHT (Kg) 5.34	ASS. NAME : Chilled Water	PART NAME: Overflow Pipe
DRAW	HAM		DWG No. : RYC-PH4-ST1-WSD-PRO-33-101-004-D00	
CHECK	ABV		SCALE 1:3	SHEET 1 OF 1
APP.	RYC			SIZE : A4

Index	Date	Comment / Change

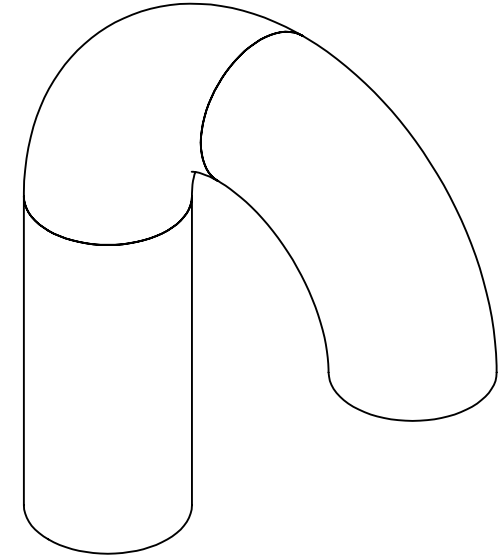
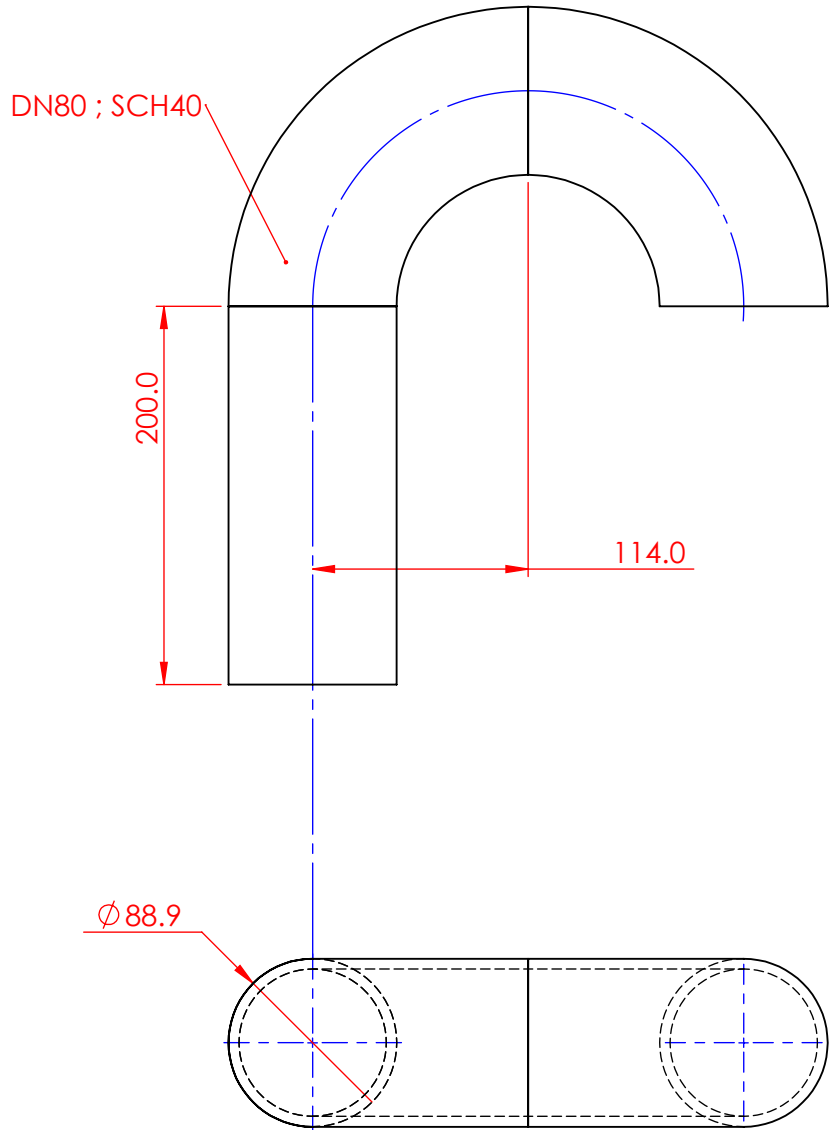

Razavi Yeast Company

Expansion Project  
Phase IV, Step 1



Client: Razavi Yeast Co

Supplier: ABV Eng & Technology

	NAME	MATERIAL A560	TITLE : Chilled Water Tank 2	TAG NUMBER : 33-T-101
DESIGN	ABV	WEIGHT (Kg) 6.18	ASS. NAME : Chilled Water	PART NAME: Vent Pipe
DRAW	HAM			
CHECK	ABV		DWG No. : RYC-PH4-ST1-WSD-PRO-33-101-005-D00	
APP.	RYC		SCALE 1:4	SHEET 1 OF 1
				SIZE : A4

Index	Date	Comment / Change

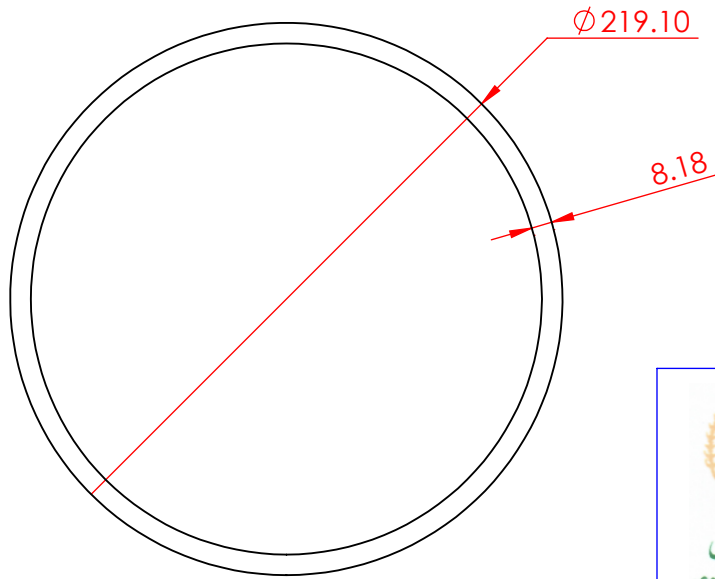
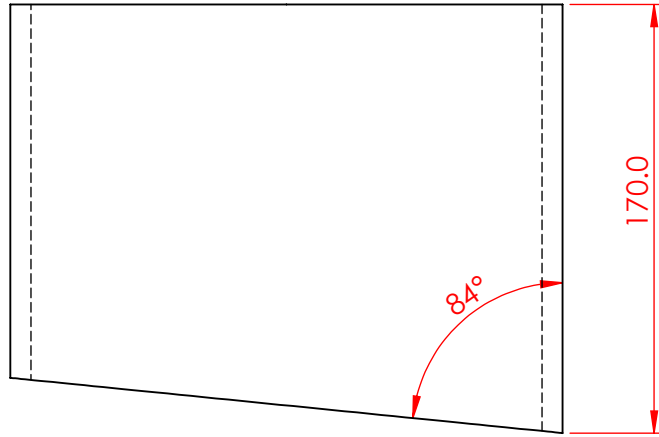

Razavi Yeast Company

**Expansion Project  
Phase IV, Step 1**

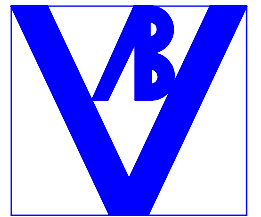

Client: Razavi Yeast Co

Supplier: ABV Eng & Technology

	NAME	MATERIAL A560	TITLE : Chilled Water Tank 2	TAG NUMBER : 33-T-101
DESIGN	ABV	WEIGHT (Kg) 6.64	ASS. NAME : Chilled Water	PART NAME: Inlet Pipe
DRAW	HAM		DWG No. : RYC-PH4-ST1-WSD-PRO-33-101-006-D00	
CHECK	ABV		SCALE 1:3	SHEET 1 OF 1
APP.	RYC			SIZE : A4

Index	Date	Comment / Change



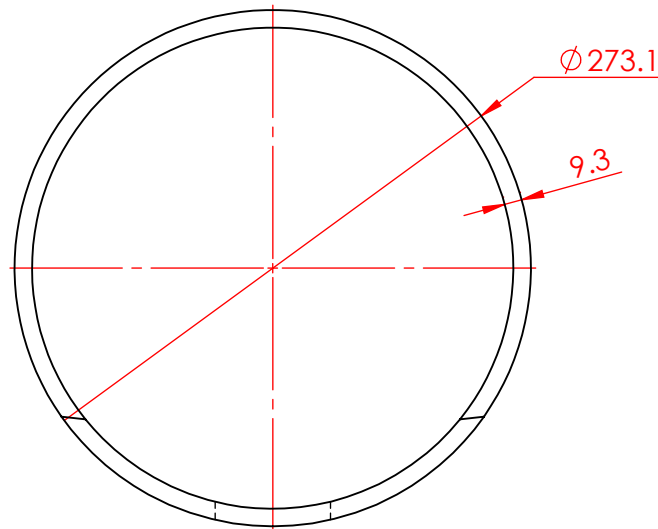
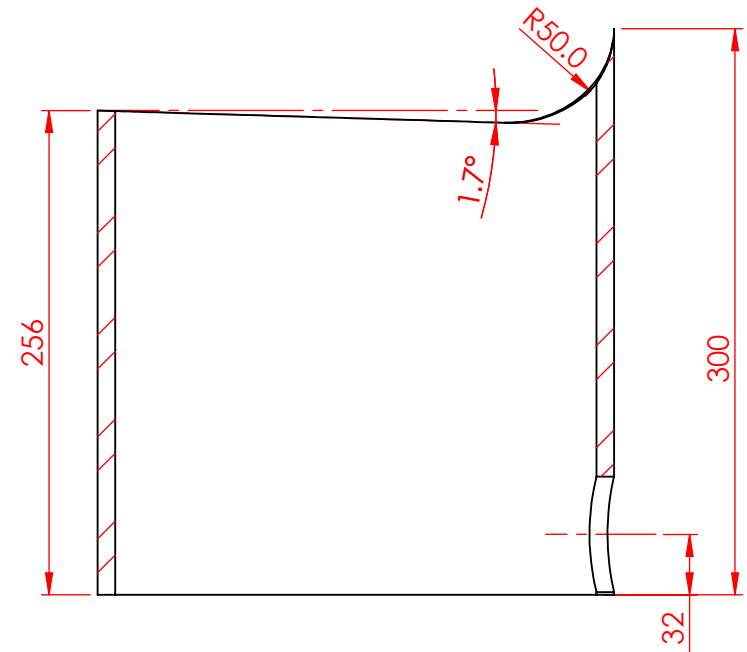
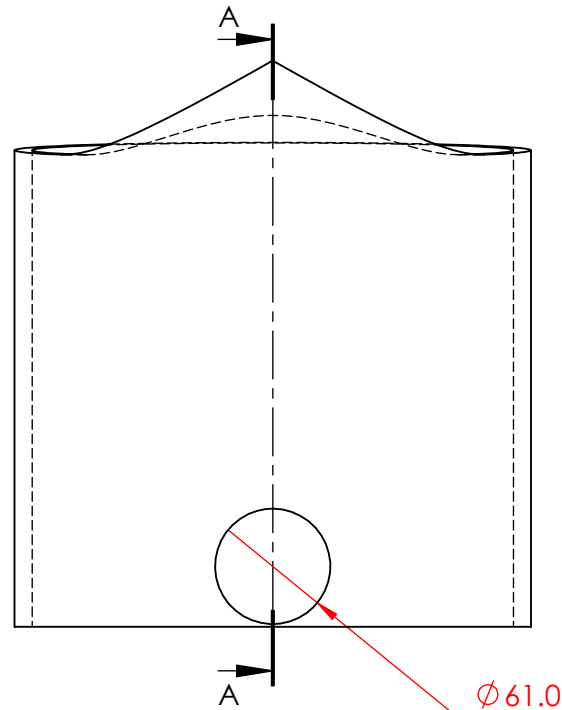

Index	Date	Comment / Change



آستان قدس  
شرکت خمیرمایه رضوی  
(سهامی خاص)

**Razavi Yeast Company**

**Expansion Project  
Phase IV, Step 1**



**Client: Razavi Yeast Co** **Supplier: ABV Eng & Technology**

	NAME	MATERIAL <b>A560</b>	TITLE : <b>Chilled Water Tank 2</b>	TAG NUMBER : <b>33-T-101</b>
DESIGN	ABV	WEIGHT (Kg) <b>14.96</b>	ASS. NAME : <b>Chilled Water</b>	PART NAME: <b>Drain</b>
DRAW	HAM		DWG No. : <b>RYC-PH4-ST1-WSD-PRO-33-101-007-D00</b>	
CHECK	ABV		SCALE <b>1:4</b>	SHEET <b>1 OF 1</b>
APP.	RYC			SIZE : <b>A4</b>

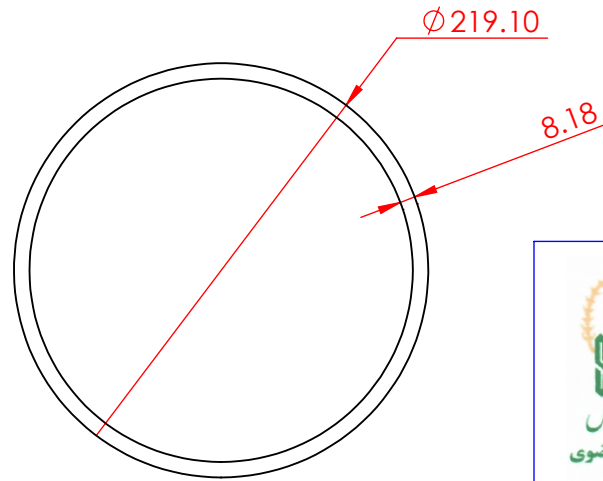
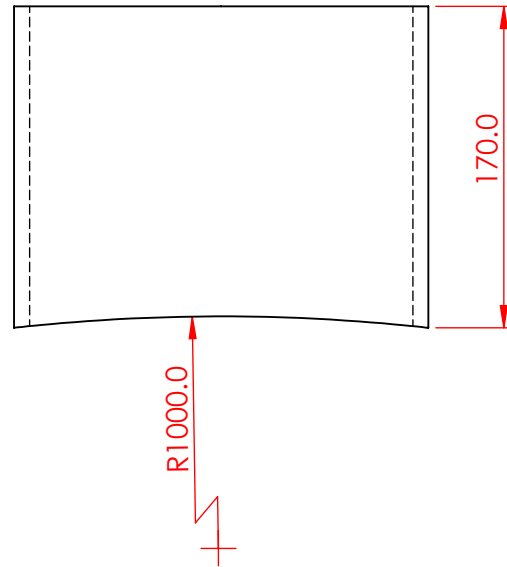

Razavi Yeast Company

**Expansion Project  
Phase IV, Step 1**

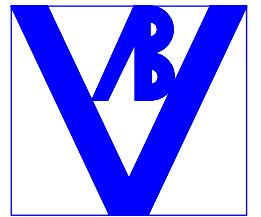

Client: Razavi Yeast Co

Supplier: ABV Eng & Technology

	NAME	MATERIAL A560	TITLE : <b>Chilled Water Tank 2</b>	TAG NUMBER : <b>33-T-101</b>
DESIGN	ABV	WEIGHT (Kg) 6.96	ASS. NAME : Chilled Water	PART NAME: Outlet Pipe
DRAW	HAM		DWG No. : RYC-PH4-ST1-WSD-PRO-33-101-008-D00	
CHECK	ABV		SCALE 1:4	SHEET 1 OF 1
APP.	RYC			SIZE : A4

Index	Date	Comment / Change

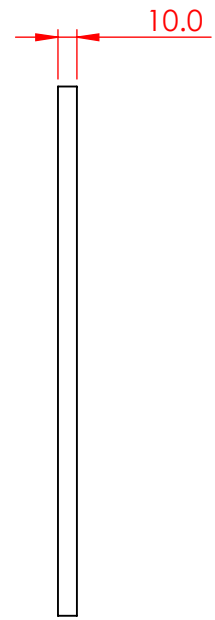
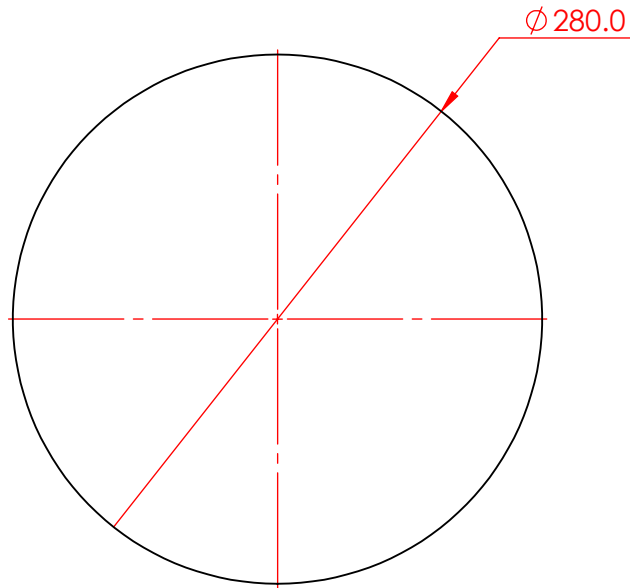

Razavi Yeast Company

**Expansion Project  
Phase IV, Step 1**

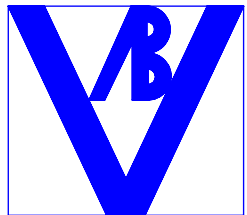

Client: Razavi Yeast Co

Supplier: ABV Eng & Technology

	NAME	MATERIAL A560	TITLE : Chilled Water Tank 2	TAG NUMBER : 33-T-101
DESIGN	ABV	WEIGHT (Kg) 4.74	ASS. NAME : Chilled Water	PART NAME: Cap Plate
DRAW	HAM		DWG No. : RYC-PH4-ST1-WSD-PRO-33-101-009-D00	
CHECK	ABV		SCALE 1:4	SHEET 1 OF 1
APP.	RYC			SIZE : A4

Index	Date	Comment / Change

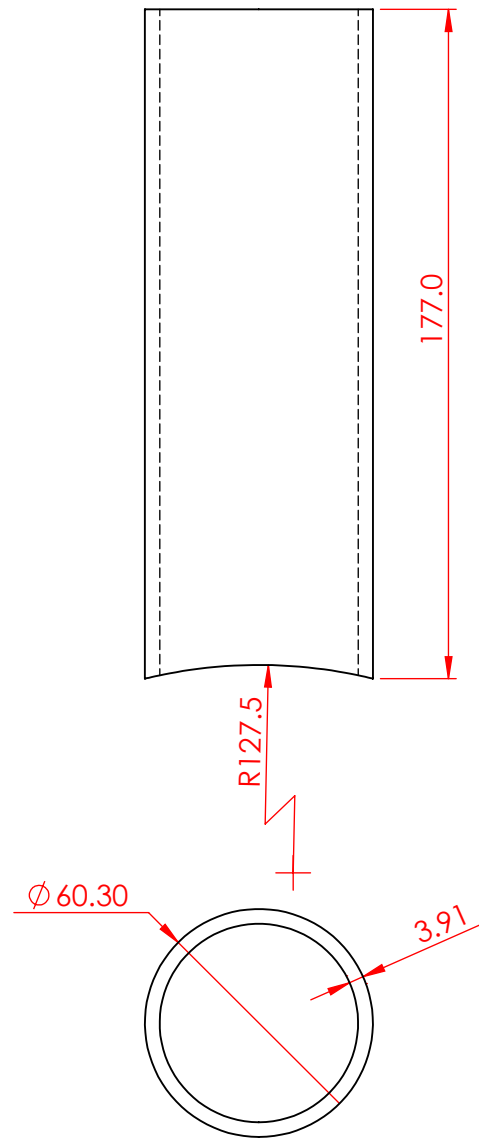

Razavi Yeast Company

**Expansion Project  
Phase IV, Step 1**



Client: Razavi Yeast Co

Supplier: ABV Eng & Technology

	NAME	MATERIAL A560	TITLE : Chilled Water Tank 2	TAG NUMBER : 33-T-101
DESIGN	ABV	WEIGHT (Kg) 0.93	ASS. NAME : Chilled Water	PART NAME: Drain Pipe
DRAW	HAM		DWG No. : RYC-PH4-ST1-WSD-PRO-33-101-010-D00	
CHECK	ABV		SCALE 1:2	SHEET 1 OF 1
APP.	RYC			SIZE : A4

Index	Date	Comment / Change

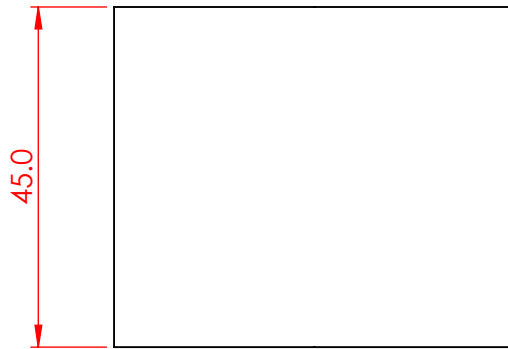
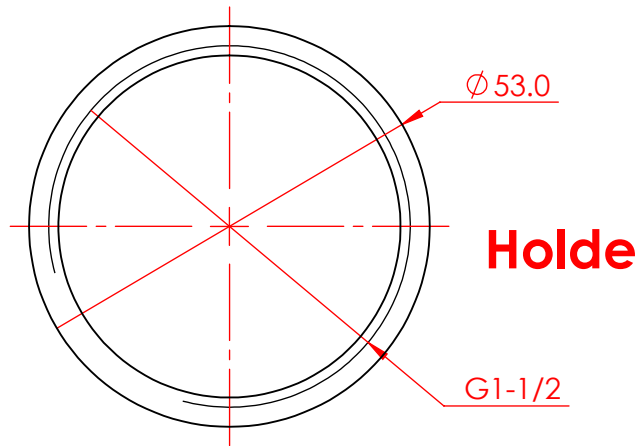

Razavi Yeast Company

**Expansion Project  
Phase IV, Step 1**

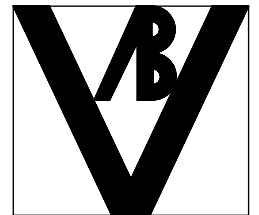

Client: Razavi Yeast Co

Supplier: ABV Eng & Technology

	NAME	MATERIAL A560	TITLE : Chilled Water Tank 2	TAG NUMBER : 33-T-101
DESIGN	ABV	WEIGHT (Kg) 0.21	ASS. NAME : Chilled Water	PART NAME: Level Socket
DRAW	HAM		DWG No. : RYC-PH4-ST1-WSD-PRO-33-101-011-D00	
CHECK	ABV		SCALE 1:1	SHEET 1 OF 1
APP.	RYC			SIZE : A4

Index	Date	Comment / Change

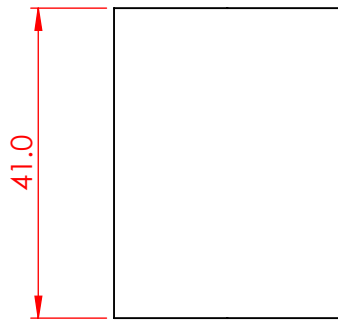
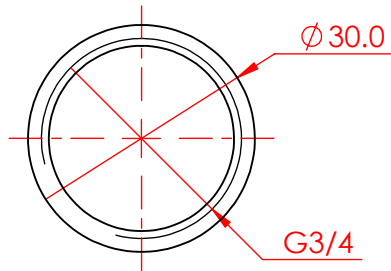

Razavi Yeast Company

Expansion Project  
Phase IV, Step 1

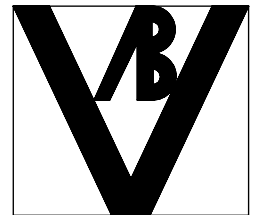

Client: Razavi Yeast Co

Supplier: ABV Eng & Technology

	NAME	MATERIAL A560	TITLE : Chilled Water Tank 2	TAG NUMBER : 33-T-101
DESIGN	ABV	WEIGHT (Kg) 0.07	ASS. NAME : Chilled Water	PART NAME: Temperature Socket
DRAW	HAM		DWG No. : RYC-PH4-ST1-WSD-PRO-33-101-012-D00	
CHECK	ABV		SCALE 1:1	SHEET 1 OF 1
APP.	RYC			SIZE : A4

Index	Date	Comment / Change

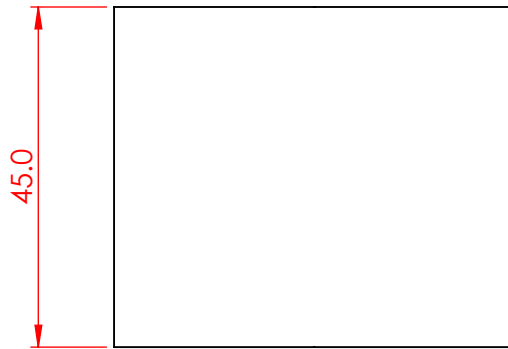
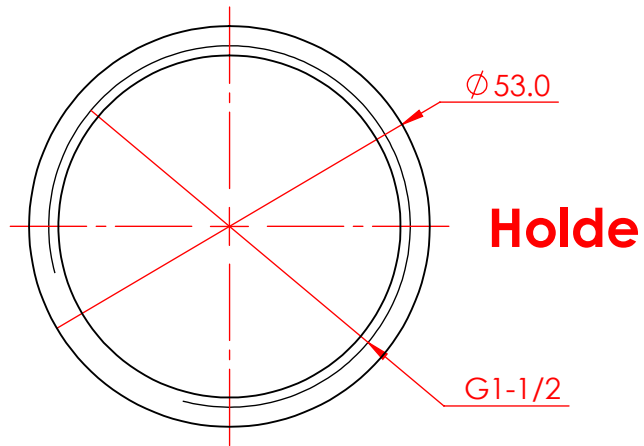

Razavi Yeast Company

**Expansion Project  
Phase IV, Step 1**

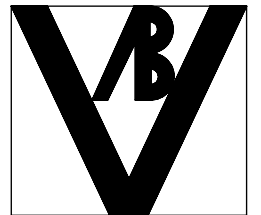

Client: Razavi Yeast Co

Supplier: ABV Eng & Technology

	NAME	MATERIAL A560	TITLE : Chilled Water Tank 2	TAG NUMBER : 33-T-101
DESIGN	ABV	WEIGHT (Kg) 0.21	ASS. NAME : Chilled Water	PART NAME: Pressure Socket
DRAW	HAM		DWG No. : RYC-PH4-ST1-WSD-PRO-33-101-013-D00	
CHECK	ABV		SCALE 1:1	SHEET 1 OF 1
APP.	RYC			SIZE : A4

Index	Date	Comment / Change

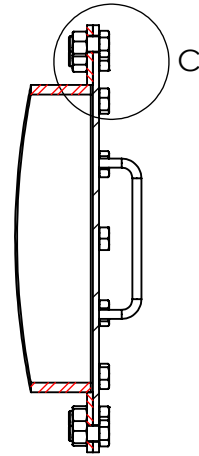
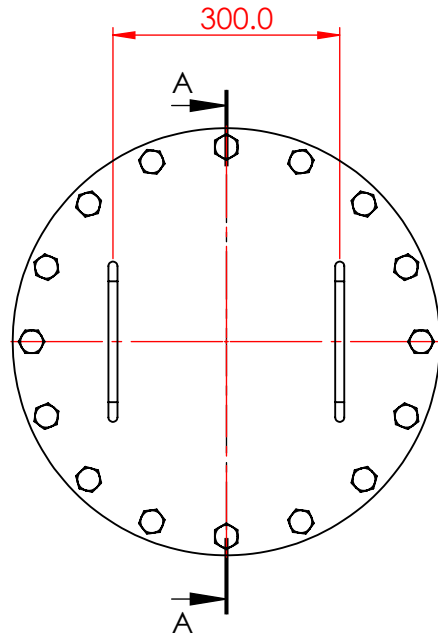

SECTION A-A

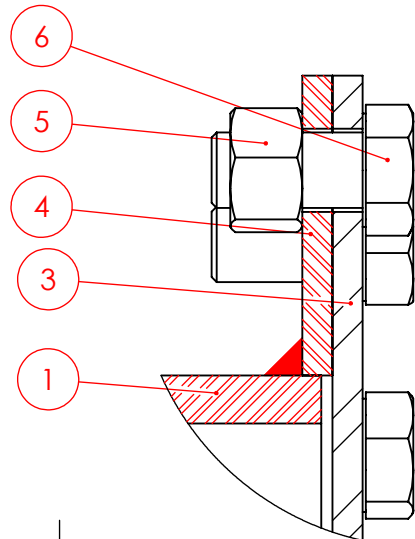
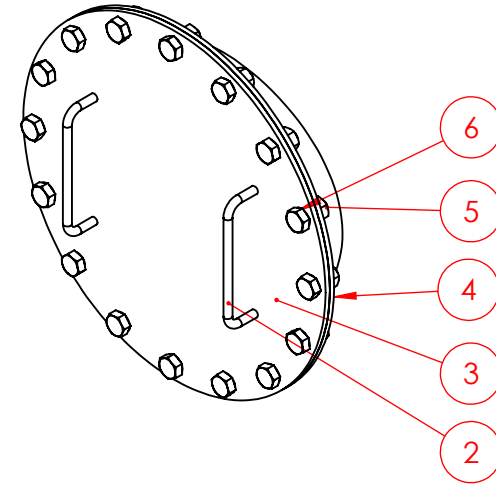

DETAIL C  
SCALE 1 : 2

Item	Drawing Number	Rev.	Part Name	Description	Material	QTY.	Weight (Kg)
6	RYC-PH4-ST1-WSD-PRO-33-101-106-D00		Hex Bolt	M20x40 ; DIN 931	A560	16	0.1761
5	RYC-PH4-ST1-WSD-PRO-33-101-105-D00		Hex Nut	M20 ; DIN 934	A560	16	0.078
4	RYC-PH4-ST1-WSD-PRO-33-101-104-D00		Flange 2	---	A560	1	7.08
3	RYC-PH4-ST1-WSD-PRO-33-101-103-D00		Flange 1	---	A560	1	15.07
2	RYC-PH4-ST1-WSD-PRO-33-101-102-D00		Handle	---	A560	2	0.25
1	RYC-PH4-ST1-WSD-PRO-33-101-101-D00		Connection Pipe	DN400 ; SCH40	A560	1	10.75



Razavi Yeast Company

Expansion Project  
Phase IV, Step 1

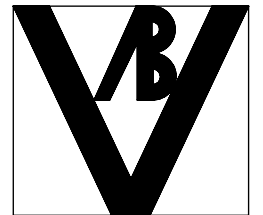

Client: Razavi Yeast Co

Supplier: ABV Eng & Technology

NAME	MATERIAL	TITLE :	TAG NUMBER :
---	---	<b>Chilled Water Tank 2</b>	<b>33-T-101</b>
DESIGN	ABV	ASS. NAME :	PART NAME:
DRAW	HAM	<b>Chilled Water</b>	<b>Side Handhole 400</b>
CHECK	ABV	DWG No. : RYC-PH4-ST1-WSD-PRO-33-101-100-D00	
APP.	RYC	SCALE 1:10	SHEET 1 OF 1
			SIZE : A4

Index	Date	Comment / Change



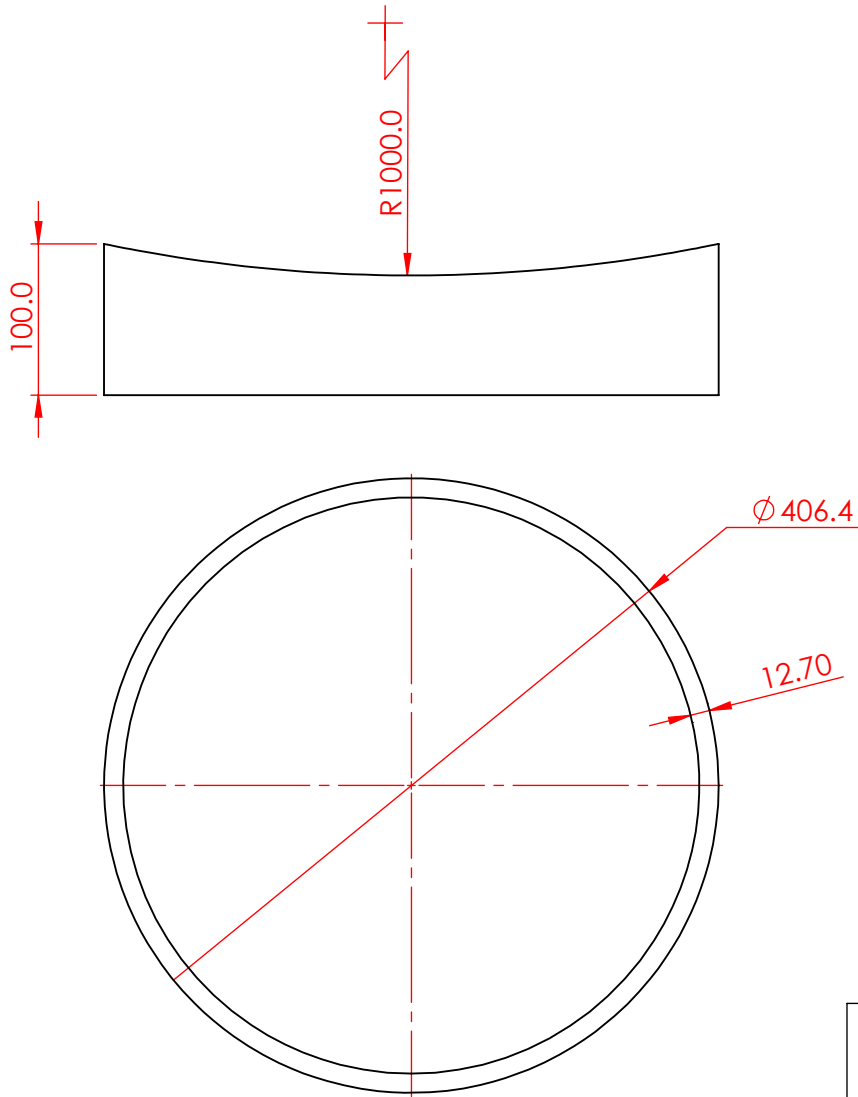

Razavi Yeast Company

**Expansion Project  
Phase IV, Step 1**

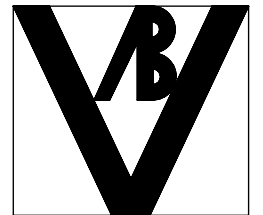

Client: Razavi Yeast Co

Supplier: ABV Eng & Technology

	NAME	MATERIAL A560	TITLE : Chilled Water Tank 2	TAG NUMBER : 33-T-101
DESIGN	ABV	WEIGHT (Kg) 10.75	ASS. NAME : Side Handhole 400	PART NAME: Connection Pipe
DRAW	HAM		DWG No. : RYC-PH4-ST1-WSD-PRO-33-101-101-D00	
CHECK	ABV		SCALE 1:5	SHEET 1 OF 1
APP.	RYC			SIZE : A4

Index	Date	Comment / Change

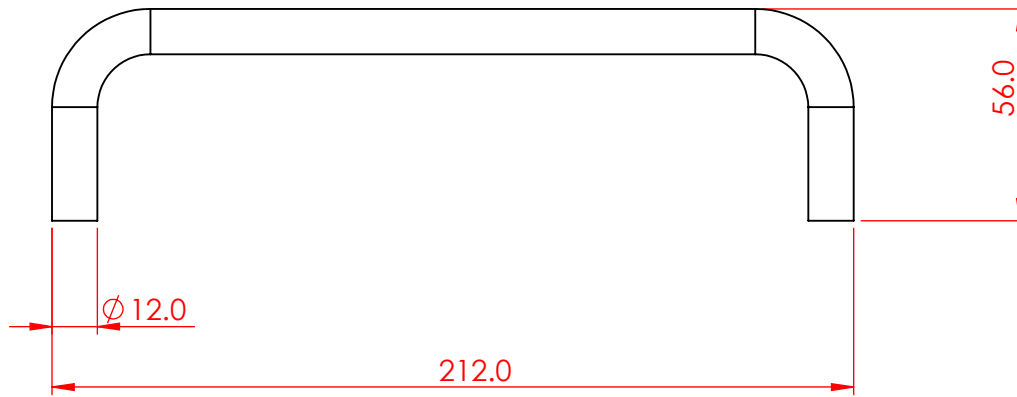

Razavi Yeast Company

**Expansion Project  
Phase IV, Step 1**

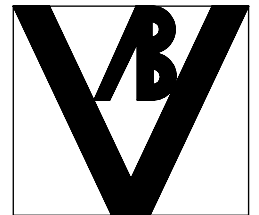

Client: Razavi Yeast Co

Supplier: ABV Eng & Technology

	NAME	MATERIAL A560	TITLE : <b>Chilled Water Tank 2</b>	TAG NUMBER : <b>33-T-101</b>
DESIGN	ABV	WEIGHT (Kg) 0.25	ASS. NAME : <b>Side Handhole 400</b>	PART NAME: <b>Handle</b>
DRAW	HAM		DWG No. : <b>RYC-PH4-ST1-WSD-PRO-33-101-102-D00</b>	
CHECK	ABV		SCALE 1:2	SHEET 1 OF 1
APP.	RYC			SIZE : <b>A4</b>

Index	Date	Comment / Change

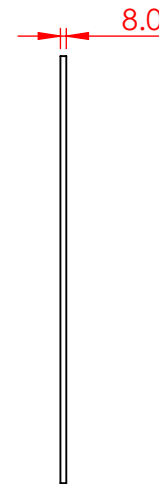
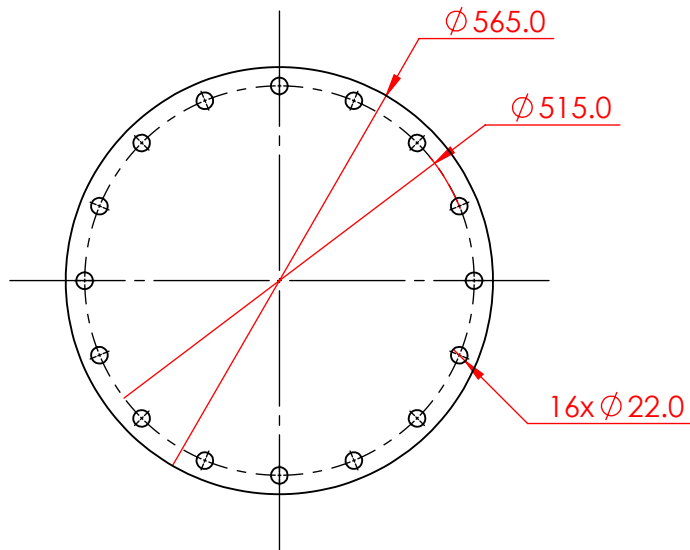

Razavi Yeast Company

**Expansion Project  
Phase IV, Step 1**

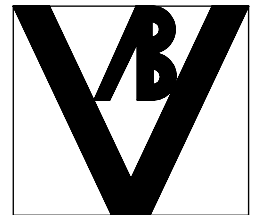

Client: Razavi Yeast Co

Supplier: ABV Eng & Technology

	NAME	MATERIAL A560	TITLE : <b>Chilled Water Tank 2</b>	TAG NUMBER : <b>33-T-101</b>
DESIGN	ABV	WEIGHT (Kg) 15.07	ASS. NAME : <b>Side Handhole 400</b>	PART NAME: <b>Flange 1</b>
DRAW	HAM		DWG No. : <b>RYC-PH4-ST1-WSD-PRO-33-101-103-D00</b>	
CHECK	ABV		SCALE 1:10	SHEET 1 OF 1
APP.	RYC			SIZE : A4

Index	Date	Comment / Change

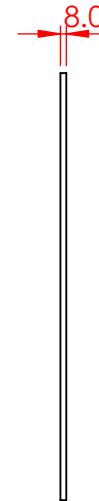
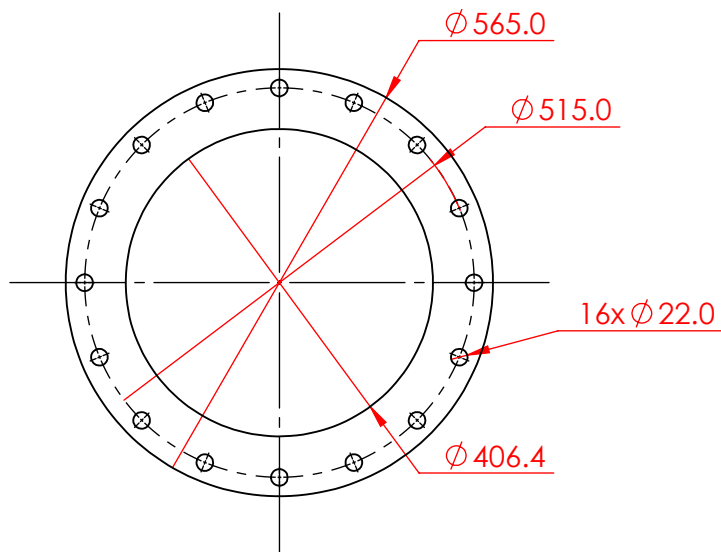

Razavi Yeast Company

**Expansion Project  
Phase IV, Step 1**



Client: Razavi Yeast Co

Supplier: ABV Eng & Technology

	NAME	MATERIAL A560	TITLE : Chilled Water Tank 2	TAG NUMBER : 33-T-101
DESIGN	ABV	WEIGHT (Kg) 7.08	ASS. NAME : Side Handhole 400	PART NAME: Flange 2
DRAW	HAM			
CHECK	ABV	DWG No. : RYC-PH4-ST1-WSD-PRO-33-101-104-D00		
APP.	RYC	SCALE 1:10	SHEET 1 OF 1	SIZE : A4

Index	Date	Comment / Change

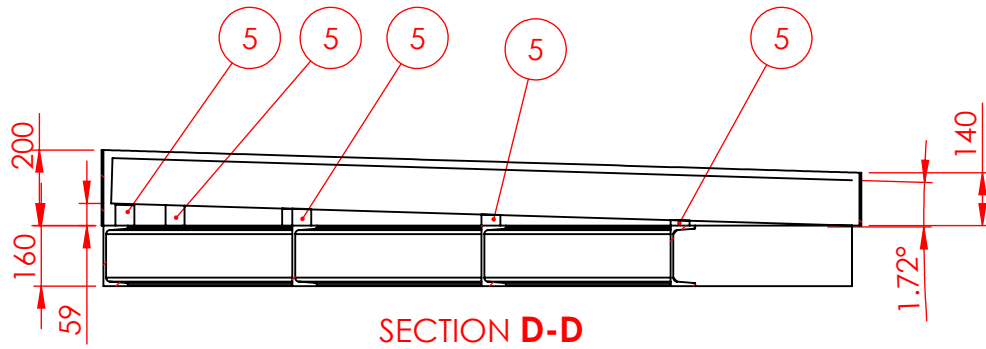

SECTION D-D

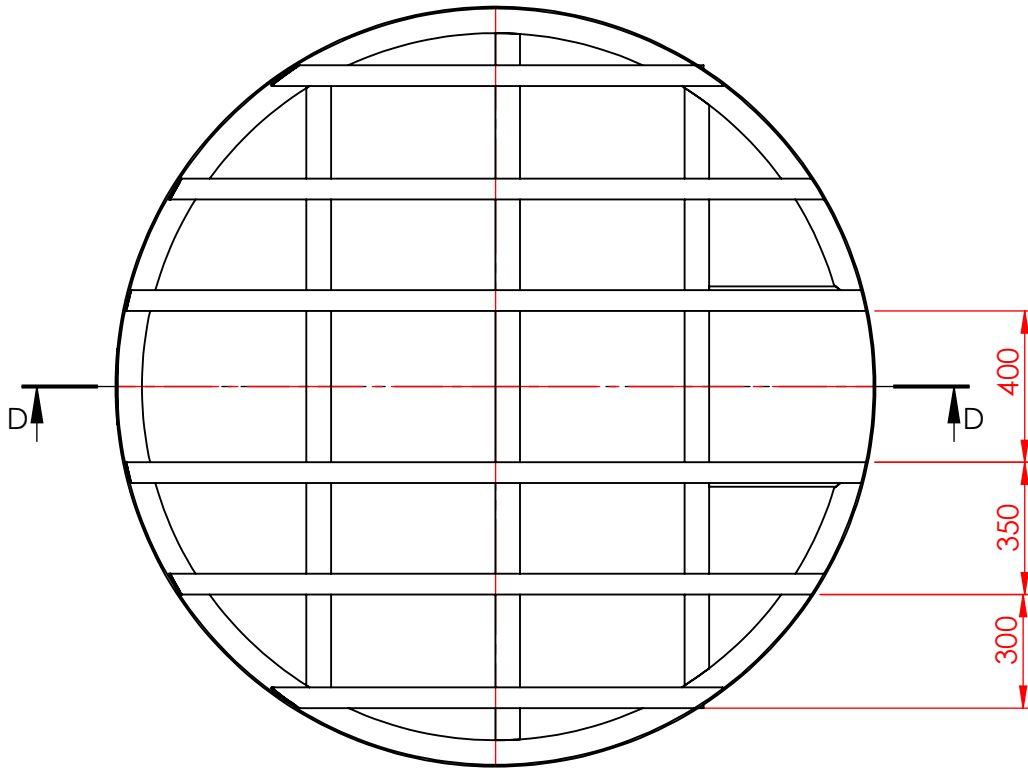
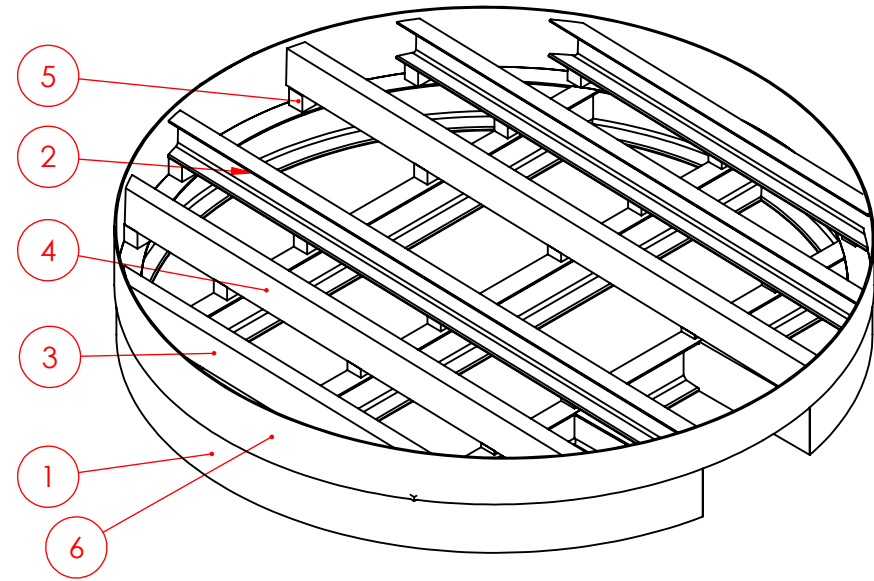

Item	Drawing Number	Rev.	Part Name	Description	Material	QTY.	Weight (Kg)
6	RYC-PH4-ST1-WSD-PRO-33-101-206-D00		Outside Ring	---	St 37	1	41.22 41
5	RYC-PH4-ST1-WSD-PRO-33-100-205-D00		Middle Parts	---	St 37	22	0.27 0
4	RYC-PH4-ST1-WSD-PRO-33-101-204-D00		Bottom Part 2	---	St 37	2	22.07 44
3	RYC-PH4-ST1-WSD-PRO-33-101-203-D00		Bottom Part 3	---	St 37	2	14.32 28
2	RYC-PH4-ST1-WSD-PRO-33-101-202-D00		Bottom Part 1	---	St 37	2	25.55 52
1	RYC-PH4-ST1-WSD-PRO-33-101-201-D00		Bottom Ring	---	St 37	1	217.92 218



Razavi Yeast Company

Expansion Project  
Phase IV, Step 1

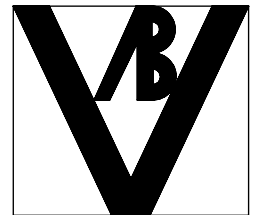

Client: Razavi Yeast Co

Supplier: ABV Eng & Technology

	NAME	MATERIAL	TITLE :	TAG NUMBER :
	---	---	<b>Chilled Water Tank 2</b>	<b>33-T-101</b>
DESIGN	ABV	WEIGHT (Kg) 397.16	ASS. NAME :	PART NAME:
DRAW	HAM		<b>Chilled Water</b>	<b>Bottom Support</b>
CHECK	ABV		DWG No. : RYC-PH4-ST1-WSD-PRO-33-101-200-D00	
APP.	RYC		SCALE 1:20	SHEET 1 OF 1
				SIZE : A4

Index	Date	Comment / Change

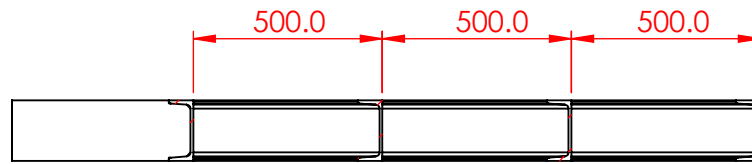
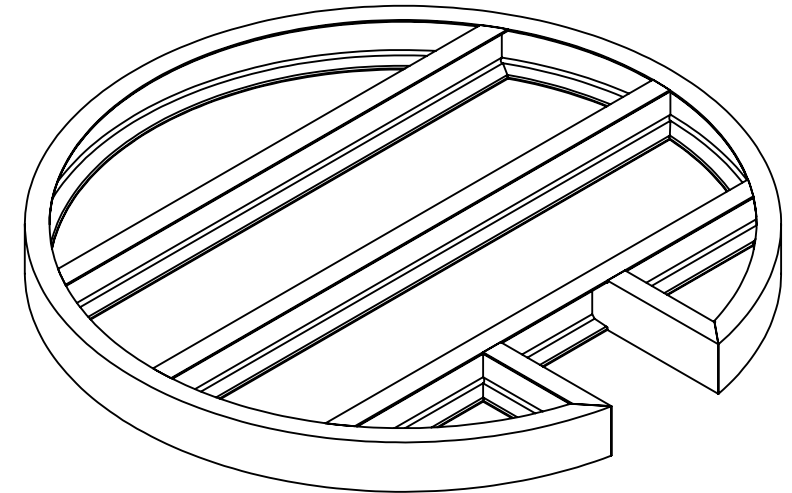
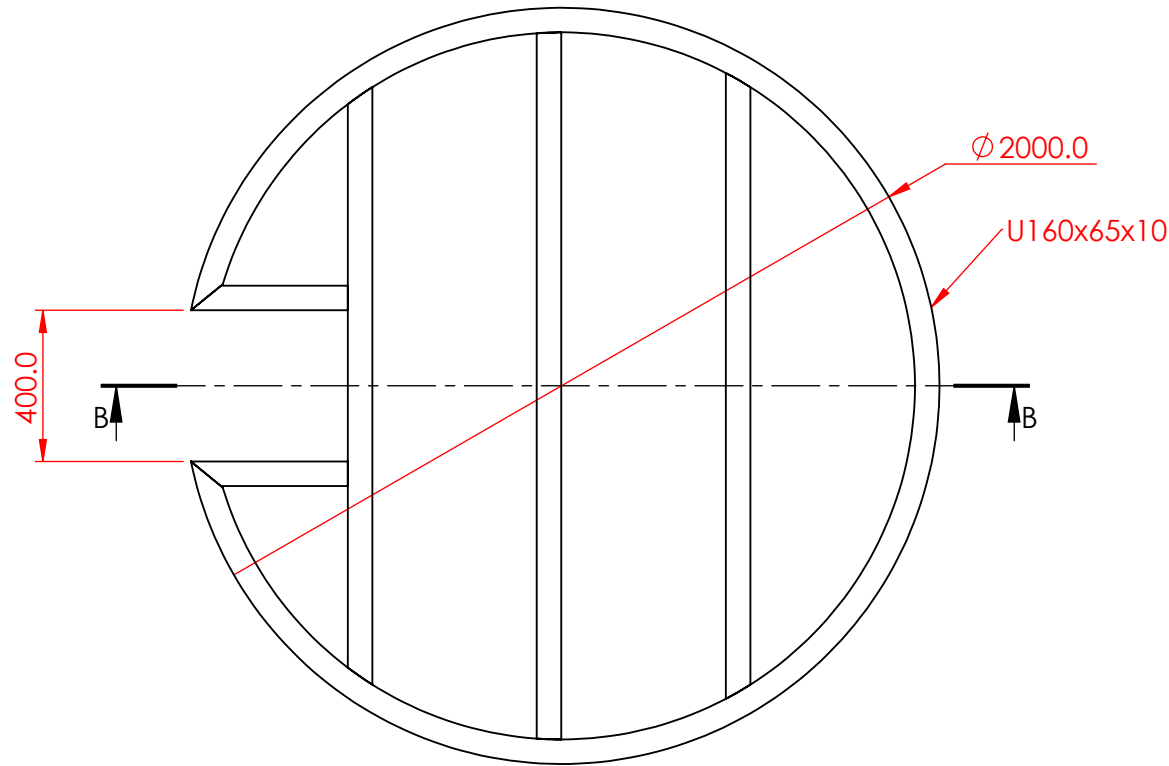

SECTION B-B



Razavi Yeast Company

Expansion Project  
Phase IV, Step 1

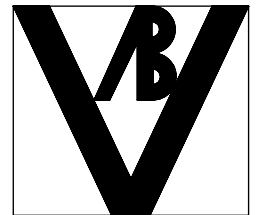

Client: Razavi Yeast Co

Supplier: ABV Eng & Technology

	NAME	MATERIAL St 37	TITLE : Chilled Water Tank 2	TAG NUMBER : 33-T-101
DESIGN	ABV	WEIGHT (Kg) 217.92	ASS. NAME : Bottom Support	PART NAME: Bottom Ring
DRAW	HAM			
CHECK	ABV		DWG No. : RYC-PH4-ST1-WSD-PRO-33-101-201-D00	
APP.	RYC		SCALE 1:20	SHEET 1 OF 1
				SIZE : A4

Index	Date	Comment / Change

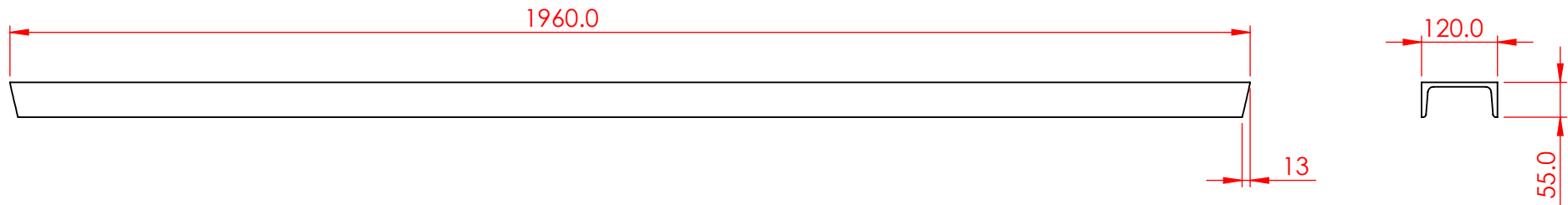

Razavi Yeast Company

**Expansion Project  
Phase IV, Step 1**

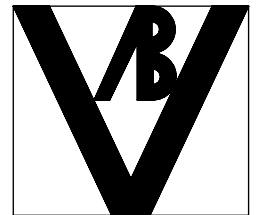

Client: Razavi Yeast Co

Supplier: ABV Eng & Technology

	NAME	MATERIAL St 37	TITLE : Chilled Water Tank 2	TAG NUMBER : 33-T-101
DESIGN	ABV	WEIGHT (Kg) 25.55	ASS. NAME : Bottom Support	PART NAME: Bottom Part 1
DRAW	HAM		DWG No. : RYC-PH4-ST1-WSD-PRO-33-101-202-D00	
CHECK	ABV		SCALE 1:10	SHEET 1 OF 1
APP.	RYC			SIZE : A4

Index	Date	Comment / Change

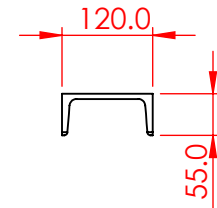
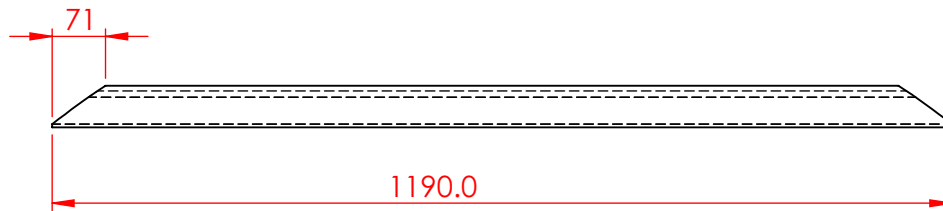

Razavi Yeast Company

Expansion Project  
Phase IV, Step 1

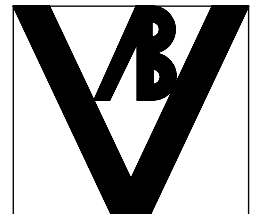

Client: Razavi Yeast Co

Supplier: ABV Eng & Technology

Index	Date	Comment / Change

NAME	MATERIAL	TITLE :	TAG NUMBER :
	St 37	Chilled Water Tank 2	33-T-101
DESIGN	ABV	ASS. NAME :	PART NAME:
DRAW	HAM	Bottom Support	Bottom Part 3
CHECK	ABV	DWG No. : RYC-PH4-ST1-WSD-PRO-33-101-203-D00	
APP.	RYC	SCALE 1:10	SHEET 1 OF 1
			SIZE : A4



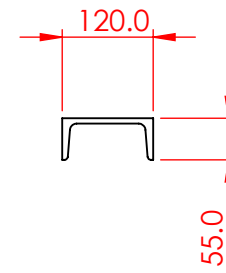
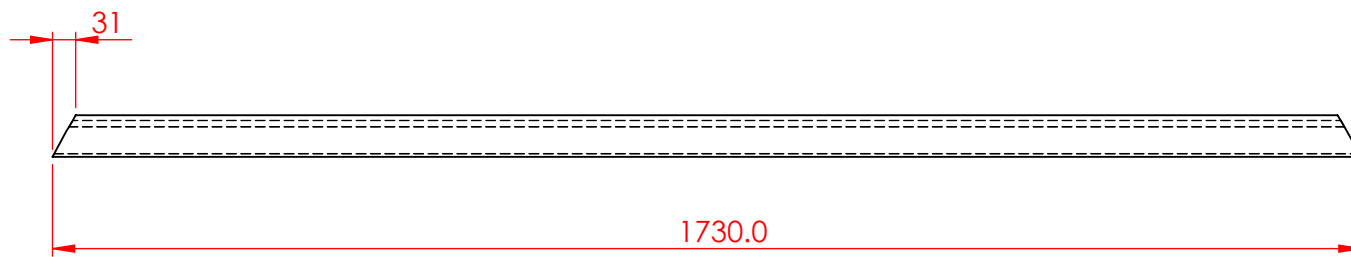

Razavi Yeast Company

**Expansion Project  
Phase IV, Step 1**

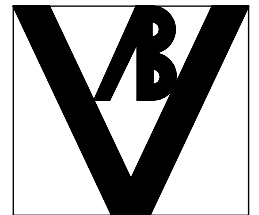

Client: Razavi Yeast Co

Supplier: ABV Eng & Technology

	NAME	MATERIAL St 37	TITLE : Chilled Water Tank 2	TAG NUMBER : 33-T-101
DESIGN	ABV	WEIGHT (Kg) 22.07	ASS. NAME : Bottom Support	PART NAME: Bottom Part 2
DRAW	HAM		DWG No. : RYC-PH4-ST1-WSD-PRO-33-101-204-D00	
CHECK	ABV		SCALE 1:10	SHEET 1 OF 1
APP.	RYC			SIZE : A4

Index	Date	Comment / Change

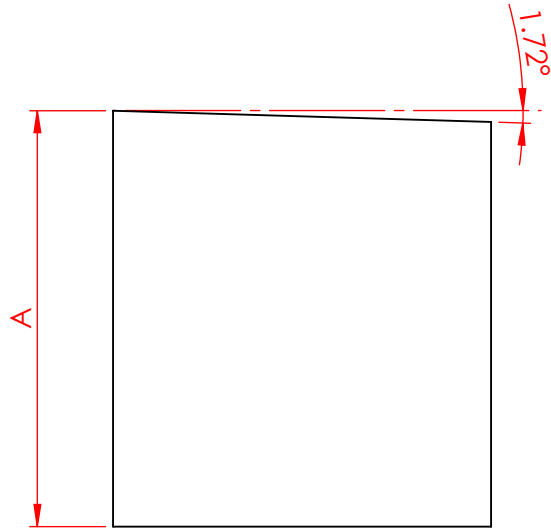

**Notes:**  
**A = Adjust base on installation position**

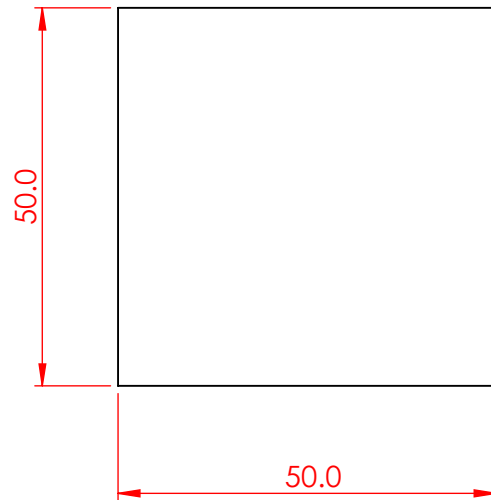

Razavi Yeast Company

**Expansion Project  
Phase IV, Step 1**

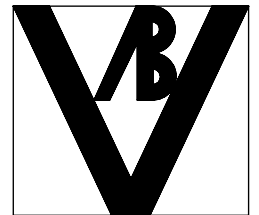

Client: Razavi Yeast Co

Supplier: ABV Eng & Technology

	NAME	MATERIAL St 37	TITLE : Chilled Water Tank 2	TAG NUMBER : 33-T-101
DESIGN	ABV	WEIGHT (Kg) 1.04	ASS. NAME : Bottom Support	PART NAME: Middle Parts
DRAW	HAM			
CHECK	ABV		DWG No. : RYC-PH4-ST1-WSD-PRO-33-101-205-D00	
APP.	RYC		SCALE 1:1	SHEET 1 OF 1
				SIZE : A4

Index	Date	Comment / Change

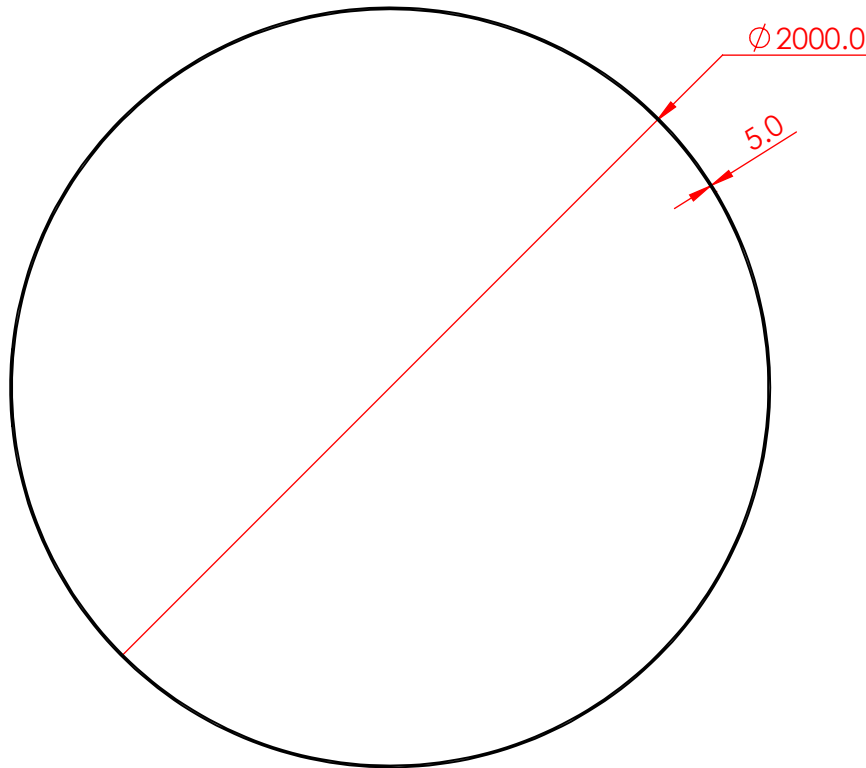
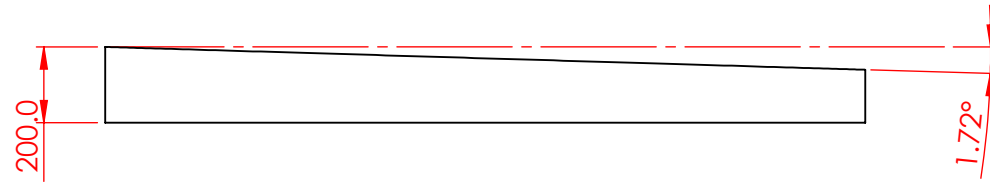

Razavi Yeast Company

**Expansion Project  
Phase IV, Step 1**

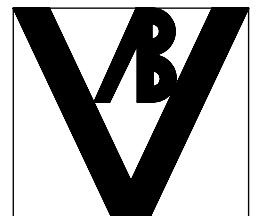

Client: Razavi Yeast Co

Supplier: ABV Eng & Technology

	NAME	MATERIAL St 37	TITLE : Chilled Water Tank 2	TAG NUMBER : 33-T-101
DESIGN	ABV	WEIGHT (Kg) 41.22	ASS. NAME : Bottom Support	PART NAME: Outside Ring
DRAW	HAM		DWG No. : RYC-PH4-ST1-WSD-PRO-33-101-206-D00	
CHECK	ABV		SCALE 1:20	SHEET 1 OF 1
APP.	RYC			SIZE : A4

Index	Date	Comment / Change